

LEVANTE

the sculptor of light



AYRTON

Digital Lighting



Levante the sculptor of light

Just as a sculptor gives life to a lifeless block of raw stone, a designer can create emotion by carving light with Levante... the new light-sculpturing wash luminaire by Ayrton.

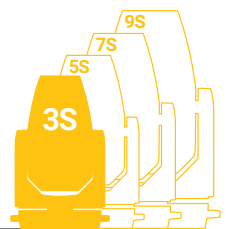

Superimpose, juxtapose, multiply, structure, carve, open up, layer... Levante is a light-sculpturing wash luminaire that will free your imagination.

Ayrton has created Levante with the same radical approach as with Bora miniaturising the wash light in an ultra-compact format and endowing it with outstanding performance capabilities.



3 Series - Source
300 W - 7000 K
 Levante-S

Lumens
20,600
 Levante-S

Native CRI
greater than 90
 Levante-TC

Beam Aperture
6.9° to 57°

Front Lens
138 mm



Levante is available in two versions: the S and the TC

The "S" version, designed for scenic applications, delivers metallic white light calibrated at 7000 Kelvin, with light output greater than 20,600 lumens, while consuming only 300 Watts.

The "TC" version of Levante is specifically geared for designers who require perfect colour reproduction. Its monochromatic light source calibrated at 6000 Kelvin has a colour rendering index greater than 90 and high TM30 readings.



With LEVANTE, Ayrton has given shape to a new art form...

A high-transmission diffusion filter was added to the zoom-lens group to erase the edge of the beam without changing its angle. A variable linear frost system allows you to adjust the desired diffusion level. Its framing module miniaturised to the extreme can sculpture scenes with amazing accuracy, allowing the four barndoors to be freely positioned on 100% of the surface area with total precision so that you can frame any object regardless of the luminaire's position.



8:1 Zoom ratio



7 rotating interchangeable metallic gobos

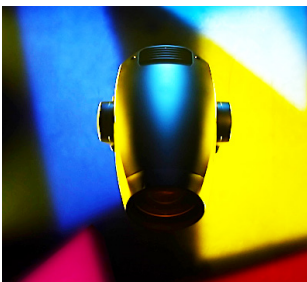

Sculpt your imagination

Levante is truly an artist's wash light, with its spherical frontal lens, proprietary 13-lens optical system and extremely uniform flat beam with no hot spot ensuring perfectly homogeneous colour mixing. Its zoom ratio, larger than 8-to-1, provides a zoom range of 6.9° to 57°. In addition to its new advanced framing system, Levante an is feature-rich from the factory with a sophisticated CMY colour-mixing system, variable colour temperature correction, a seven-position complementary colour wheel, a wheel with seven rotating interchangeable metallic gobos, a lightning-fast 15-blade iris diaphragm, a dynamic animation effect with speed and fade adjustment and an electronic dimmer allowing perfect light adjustment from 0 to 100%.

Ultra-compact format and it weighs only 22 kg





Levante, a dramatically miniaturised version of the Bora wash light, and using the same radical concept

Ayrton has masterfully fitted a 550-Watt high-efficiency power supply into a fixture based on the ultra-compact Mistral format and it weighs only 22 kilos!

Levante by Ayrton is a marvel of technology that will make you see things under a different light. Sculpturing light as you have always dreamt of exploring your imagination. Bringing your audience into another dimension offering them a dazzling experience.

In pursuit of the ultimate light-sculpturing experience, Ayrton continues to lead the way.

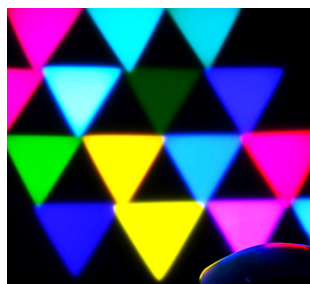
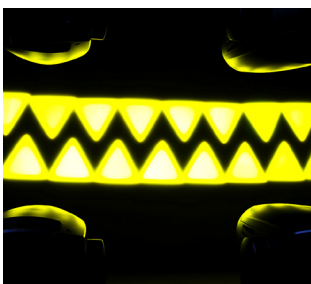
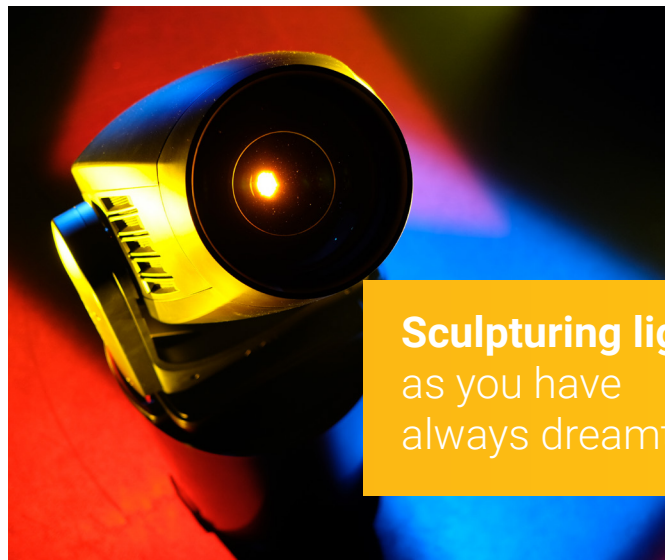

Colours



CMY colour mixing system

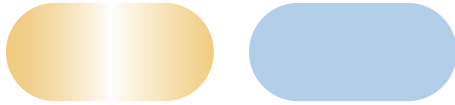

Variable CTO

1/4 CTB

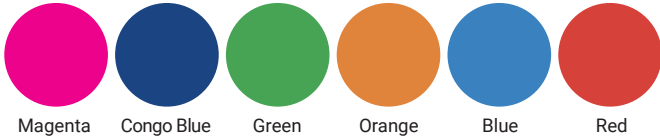

Magenta

Congo Blue

Green

Orange

Blue

Red

Gobos

Gobos Ø 25.5 mm | Image Ø 19 mm

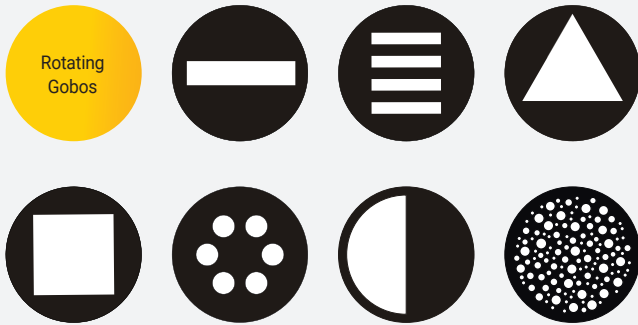

Rotating Gobos

Framing system

Iris diaphragm

Progressive frost

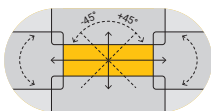

100% surface area



15% to 100% open



0% to 100%

Sparkle effect

Dimmer

Strobe

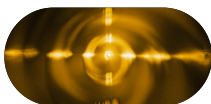

0 to 100 %

1 to 25 fl/sec.

Photometry

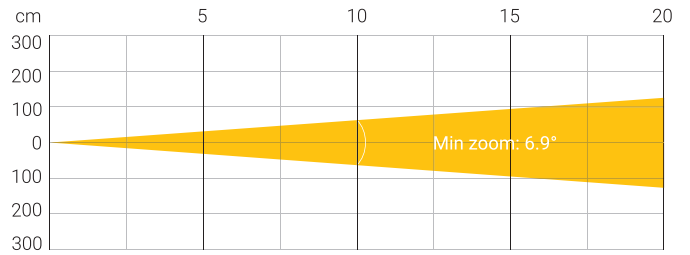

Distance (m)	5		10		15		20	
Unit	lux	Ø	lux	Ø	lux	Ø	lux	Ø
Levante-S	51,800	0.61	11,600	1.26	5,200	1.89	2,970	2.52
Levante-TC	34,900		8,550		3,870		2,140	

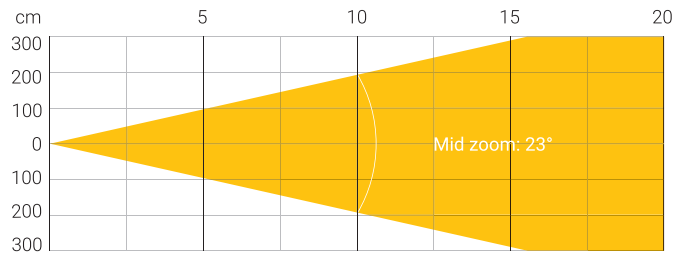

Distance (m)	5		10		15		20	
Unit	lux	Ø	lux	Ø	lux	Ø	lux	Ø
Levante-S	5,740	2.02	1,600	3.9	545	5.98	320	7.9
Levante-TC	4,580		1,070		540		310	

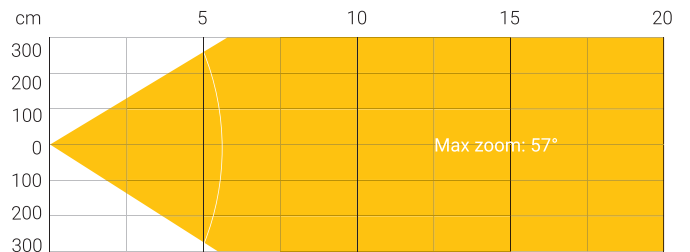

Distance (m)	5		10		15		20	
Unit	lux	Ø	lux	Ø	lux	Ø	lux	Ø
Levante-S	1,080	5.43	340	10.86	170	16.29	90	21.72
Levante-TC	730		240		120		70	

Version	Levante-S	Levante-TC
Total Flux (Integrating sphere)	20,600 lm (zoom at 35%)	14,300 lm (zoom at 35%)
CCT LED Source	8000 (±500 K)	7000 (±450 K)
CCT Luminaire	7000 (±500 K)	6000 (±450K)
Ra Luminaire	73 (Ra: >70)	90 (Ra: ±2)
TLCI	47	90
TM-30	Rf: 68.9 Rg: 94.2	Rf: 87.1 Rg: 95.3

Fan Mode (Noise Level)	Levante-S	Levante-TC
Auto Mode: 44.7 dBA	20,600 lm	14,300 lm
Silence Mode: 38.7 dBA	15,500 lm	11,600 lm
Stage Mode: 49.1 dBA	20,700 lm	14,600 lm
Studio Mode: 40.6 dBA	18,700 lm	13,600 lm

Note: noise measured at 1m distance, static status, ambient 31dBA

OPTICS

- 13-element 8:1 zoom high-resolution optic system
- Beam aperture: 6.9° to 57°
- High-speed motorised linear zoom
- Tempered anti-reflective coated lenses
- 138 mm frontal lens for greater performance

LIGHT SOURCE

LEVANTE-S

- 26,500 lumen, 8000 K white light engine
- Total luminaire output: up to 20,600 lumens
- Colour temperature output: 7000 K
- CRI: greater than 70

LEVANTE-TC

- 20,500-lumen 7000 K white light engine
- Total luminaire output: up to 14,300 lumens
- Colour temperature output: 6000 K
- CRI: greater than 90

LEVANTE-S & LEVANTE-TC

- Rated life (L70): up to 40,000 hours
- Flicker-free source management suitable for TV applications and all video-recorded events

MOVEMENT

- Highly accurate positioning
- Moving-head operated via either 8- or 16-bit resolution
- High-resolution stepper motors operated via microprocessors to ensure extreme accuracy and smooth movement
- Pan and tilt with automatic repositioning
- Moving-head range: 540° (pan), 270° (tilt)

COLOURS

- Sophisticated colour mix system providing CMY colour mixing
- Variable CTO colour temperature correction
- Fixed colour wheel with seven complementary colours

GOBOS

- 1 indexable rotating gobo wheel with 7 metallic gobos, plus an open position
- Adjustable-speed rotating gobo in both directions
- Gobo diameter: 25.5 mm
- Image diameter: 19 mm

BARNDOORS

- 4 individually positionable shutter blades on a 100% surface area in all positions
- Rotation of the barndoor system module: +/- 45°

IRIS DIAPHRAGM

- Fast iris diaphragm with adjustable dynamic effects
- Iris range: 15% to 100% open

FROST

- 0% to 100% variable linear frost

EFFECT

- Sparkle effect: dynamic animation effect with speed and fade adjustment

DIMMER / STROBE

- Electronic dimmer, allowing perfect light adjustment from 0 to 100% without colour variation
- White or colour strobe effect, with speed adjustment from 1 to 25 flashes per second

SOFTWARE FEATURES

- Local DMX addressing of luminaire and optional parameters through its built-in LCD control panel
- Remote DMX addressing of luminaire and optional parameters through a standard RDM DMX controller
- Information menu including hour counter, temperature, software version

HARDWARE FEATURES

- Graphic LCD display for addressing and special functions settings, with flip function
- Clicking jog wheel to set functions
- Excess-temperature protection
- Integrated wireless CRMX TiMo™ RDM receiver from LumenRadio™
- XLR 5 pin male and female connectors for DMX connection
- powerCON TRUE1 male and female connectors for power connection

CONTROL

- DMX 512 protocol, through DMX cable or a wireless system
- DMX-RDM compatible
- Stand-alone mode and Master/Slave modes
- Local control panel, with LCD display
- Choice of 3 DMX modes (from 29 to 50 DMX channels)

POWER SUPPLY

- Electronic supply with active PFC
- 100 to 240 Volts – 50/60 Hz
- Power: 550 W maximum

COOLING SYSTEM

- Advanced liquid cooling system
- Self-adjusting variable speed fans for quiet operation (Auto mode)
- Selectable ventilation user modes with a Silent Mode
- Safety protection against temperature excesses

HOUSING

- Moving-head skeleton made of aluminium and steel plates
- Base in die-cast aluminium
- Heatsinks in aluminium and copper
- Moulded covers in self-extinguishing fire retardant ABS PC (V0 class)
- Two-side handles for transportation
- Four heavy-duty feet for better stability
- IP20 protection rating
- Exterior finish: black (Carbon)

INSTALLATION

- Fastening brackets system: two Omega ¼ turn brackets designed for use with standard clamps
- Mounting points: four ¼ turn locking fittings allowing installation of Omega brackets on luminaire
- Safety cable attachment point

OPERATING PARAMETERS

- Operating positions: all (device on floor or fixed to a support)
- Maximum permitted ambient temperature (Ta max): 45 °C (113 °F)
- Minimum permitted ambient temperature (Ta min): -10 °C (14 °F)
- Minimum usage distance: 1.5 m (4.92 ft)

COMPLIANCE

EU (EMC & LVD):

- EMC Directive 2014/30/EU
- LVD Directive 2014/35/EU

US (SAFETY & EMC):

- UL 1573
- FCC Part 15, Subpart B: 2018

SIZE

- Product: 365 x 632 x 230 mm (l x h x d)
- Flight-case foam: 430 x 660 x 280 mm (l x h x d)

WEIGHT

- Product: 22 kg

PRODUCT CODES

- 010240: LEVANTE-S – CLASSICAL 3 SERIES
- 010250: LEVANTE-TC – CLASSICAL 3 SERIES

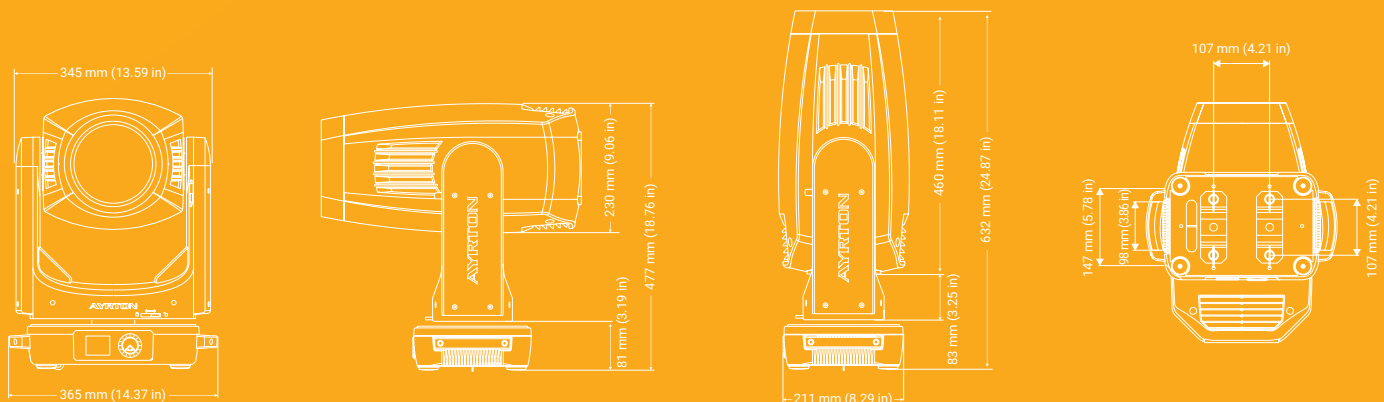



AYRTON

Digital Lighting

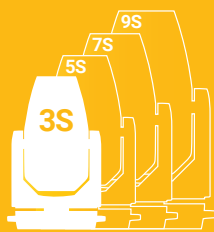

www.ayrton.eu

03.2019